

TECHNICAL DATA

SINGLE DRUM ROLLERS

BW 214 D-5

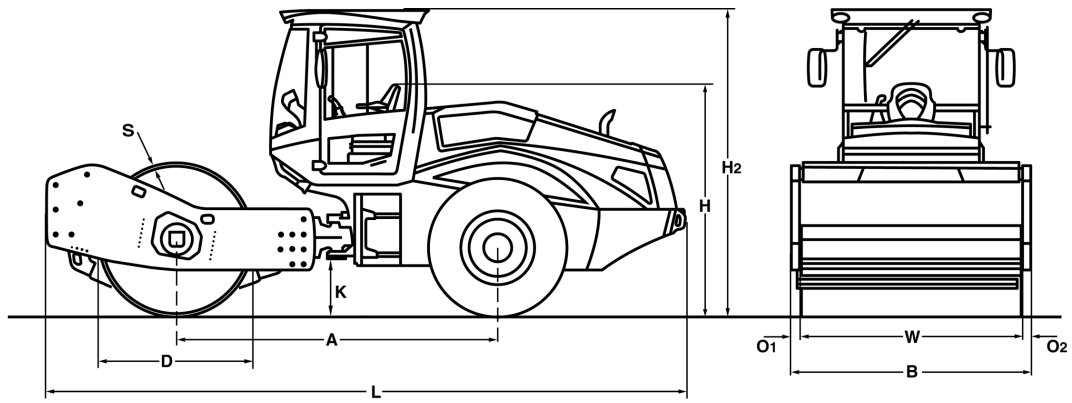



Dimensions in mm

	A	B	D	H	H2	K	L	O1	O2	S	W
BW 214 D-5	3115	2300	1500	2250	2990	490	6220	85	85	30	2130

Shipping dimensions in m3

BW 214 D-5

without ROPS

32,189

with ROPS

42,775

Machine type	Compaction output (m3/h)			
	Rock fill	Gravel, sand	Mixed soil	Silt, clay
BW 214 D-5	530-1080	360-730	270-5500	180-360

Machine type	Compacted layer thickness (m)			
	Rock fill	Gravel, sand	Mixed soil	Silt, clay
BW 214 D-5	0,90	0,65	0,50	0,25

Technical Data

BOMAG BW 214 D-5

Weights

Grossweight	kg	16.300
Operating weight CECE w. ROPS-cabin	kg	14.000
Axle load, drum CECE	kg	8.600
Axle load, wheels CECE	kg	5.400
Static linear load CECE	kg/cm	40,4

Dimensions

Working width	mm	2.130
Track radius, inner	mm	3.880

Driving Characteristics

Speed (1)	km/h	0- 5,0
Speed (2)	km/h	0- 6,0
Speed (3)	km/h	0- 8,0
Speed (4)	km/h	0- 11,0
Max. gradeability without/with vibr.	%	49/46

Drive

Engine manufacturer		Deutz
Type		TCD 3.6 L4
Emission stage		Stage V
Exhaust gas aftertreatment		DOC+DPF+SCR
Cooling		Liquid
Number of cylinders		4
Performance ISO 3046	kW	95,0
Performance SAE J 1995	hp	128,0
Speed	min-1	2.000
Fuel		Diesel
Electric equipment	V	12
Drive system		hydrost.
Drum driven		standard

Drums and Tyres

Tyre size		23.1-26 12PR
-----------------	--	--------------

Brakes

Service brake		hydrost.
Parking brake		hydromec.

Steering

Steering system		oscil.artic.
Steering method		hydrost.
Steering / oscillating angle +/-	grad	35/12

Exciter system

Drive system		hydrost.
Frequency	Hz	30/36
Amplitude	mm	2,00/1,00
Centrifugal force	kN	285/183
Centrifugal force	t	29,1/18,7

Capacities

Fuel	l	250,0
------------	---	-------

Technical modifications reserved. Machines may be shown with options.

Standard Equipment

- BOMAG ECOMODE
- Self locking differential
- Rear axle with twin spring accumulator brakes
- Hydrostatic travel and vibration drive
- Hydrostatic articulated steering
- Articulated joint lock
- Seat with arm rest and adj. for position and height
- Battery disconnect switch
- Single lever control for travel and vibration
- Warning, information and operation displays with LCD
- Loading mode
- Emergency STOP
- Working lights front / rear
- Back-up alarm
- 2 Scrapers
- Warning horn

Optional Equipment

- * ROPS/FOPS cabin with seat belts
 - Sliding window
- ROPS/FOPS with safety belt
- Rearview camera
- Air condition
- Radio (Bluetooth)
- Pre start cabin heating
- Comfort package: Adjustable seat and adjustable steering column
- Rotary beacon
- Indicator and hazard lights
- BOMAG ECOSTOP
- ECONOMIZER
- TERRAMETER
- BOMAG TELEMATIC POWER
- Special painting
- Padfoot segment kit
- Environmentally compliant hydraulic oil
- Measuring- and machine data interface for third-party suppliers
- LED Working lights (Cabin)
- Reversing alarm buzzer with broad band audio

* Standard delivery with CE conformity
(valid within European Union)#72

